



## HEALTH CARE FURNISHINGS

*Senior Living | Long Term Care | Skilled Nursing | Rehab*



# WHY TODAY'S CHAIRS **FAIL** TO MEET THE CHALLENGES OF AN AGING POPULATION



The journey of aging robs many seniors from living healthy, independent lives. Challenges associated with aging, ongoing health issues, injuries, or surgeries reduce mobility and prevent many from doing even the simple things in life, such as scooting up to a table to enjoy a meal with family or friends.

## **Simply stated...**

Today's dining chairs are outdated....because they are not designed to MOVE!

As a result, caregivers (the person behind the chair) experience fatigue and risk personal injury each time they provide mealtime assistance.

## **Therefore...**

Dining chairs designed for seniors and caregivers should include features that enable chairs to **SWIVEL...TURN...ROLL...and BRAKE for safety!**

These features eliminate the need for care staff to **push / pull / shove / twist** when providing mealtime assistance.

## **Consider the following...**

1. **Traditional chairs are not designed to move.** Traditional, four-legged dining chairs rely on friction between the legs of the chair and the floor to remain upright and immobile. Thus, any force applied to move a chair (push/pull/shove/twist) with a seated person damages a chair's structural integrity.
2. **Cushioned flooring further increases resistance when attempting to move a seated person.** While cushioned flooring is credited with minimizing serious injury should a fall occur, indentations formed under each chair leg make it almost impossible for a caregiver to move a chair with someone sitting in it.
3. **In many care communities, the person providing assistance is also a senior.** Increasingly, many early retirees are returning to work as caregivers. As seniors themselves, they too are at risk of incurring injury do to diminished physical strength and muscle coordination.
4. **Safety guidelines indicate a person can safely push no more than 40 lbs.** Any attempt to move a seated person of any size is unsafe and increases the risk of injuring oneself.



## Daily mealtime challenges experienced by caregivers include:



- Assisting persons with limited mobility get seated and moved up-to and away-from the table
- Assisting larger persons (300+ lbs.) get seated and moved up-to and away-from the table
- Assisting persons relying on a rollator/wheelchair for stability, transfer into a dining chair and then get moved up-to and away-from the table
- Providing dignity to persons requiring feeding assistance while they are seated in different styles of geri-chairs
- Providing assistance to persons who are no longer capable of understanding verbal instructions (Alzheimer's, Dementia) get seated and moved up-to and away-from the table
- Providing assistance to persons with impaired motor skills (Parkinson's) get seated and moved up-to and away-from the table

**...and finally, providing care without incurring a personal injury.**

While it is expected caregivers will assist a seated person up-to and away-from the table, the reality is this task is almost impossible as caregivers lack the physical strength required to provide assistance. Care communities would be well served to identify a mechanical means that enable caregivers to perform these tasks with grace and ease.

**Design Question:** How does a person living with reduced mobility get moved up-to and away-from the table?

**Design Challenge:** Our challenge was not to design a chair that moves easily. These chairs already exist in the form of task chairs or 70's style dinette chairs. They would be considered unsafe, as they can move unexpectedly or prematurely.

Rather, the challenge was to incorporate mobility features into the design of a chair which address each of the following concerns **without compromising safety:**

- enable a seated person to be moved up to the table with ease and grace
- reduce physical demands placed upon caregivers
- ensure the person's sense of dignity and self-worth are maintained

**To Learn More...**For seniors living with reduced mobility, these features enable a care provider to offer assistance without risk of injury to themselves.



[www.comfortek.com/T2-healthcare](http://www.comfortek.com/T2-healthcare)

# HOW DOES A PERSON GET SEATED AT THE TABLE...



POSITIONS  
CHAIR

GETS  
SEATED

LIFTS  
CHAIR  
SLIGHTLY

SCOOTs  
FORWARD



AN **ABLE-BODIED** PERSON...

REQUIRES NO ASSISTANCE



CAREGIVER  
POSITIONS  
CHAIR



CAREGIVER  
ASSISTS IN  
GETTING SEATED



CAREGIVER  
PUSHES - SHOVS - TWISTS  
TO MOVE SEATED PERSON FORWARD



A **MOBILITY-CHALLENGED** PERSON...

REQUIRES A CAREGIVER'S ASSISTANCE  
TO GET SEATED AT THE TABLE

# SPECIALIZED SEATING FOR SENIORS...AND CAREGIVERS!

Senior Living  
Long Term Care  
Skilled Nursing  
Rehab





## HOW MUCH PHYSICAL ASSISTANCE CAN A CAREGIVER SAFELY EXERT?

### ( **LIFTING - PUSHING - PULLING** )

A person can safely **LIFT 35 lbs.** under normal conditions (no sudden moves or twisting)  
A person can safely **PUSH up to 20%** of their body weight and **PULL up to 30%** of their body weight.

*\* Silverstone Group*

	LIFT 	PUSH 	PULL 
140 lbs. CAREGIVER	35 lbs.	28 lbs.	42 lbs.
200 lbs. CAREGIVER	35 lbs.	40 lbs.	60 lbs.



ESSENTIALLY...WHEN USING TRADITIONAL DINING FURNITURE,  
**A CAREGIVER RISKS A WORK-RELATED INJURY** EACH TIME MEAL ASSISTANCE IS PROVIDED.



**Traditional Seating**



SEAT: **Swivels**  
**Locks - 90°**



SEAT: **Swivels**  
**Locks - 90°**  
  
CHAIR: **Rolls (Inline)**  
**Brakes**



CHAIR: **Turns (360°)**  
**Rolls**  
**Brakes**

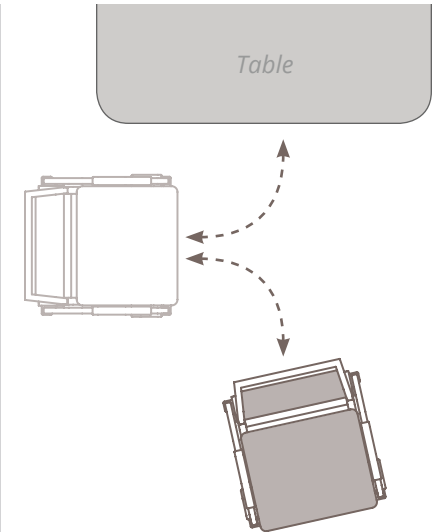
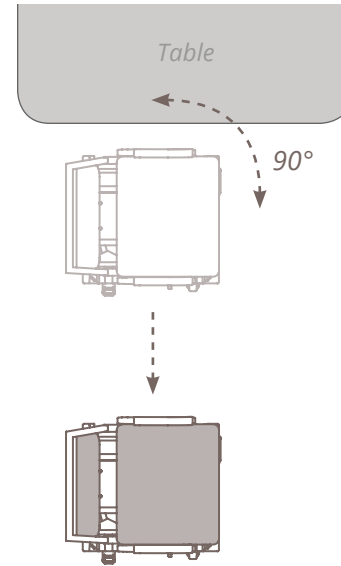
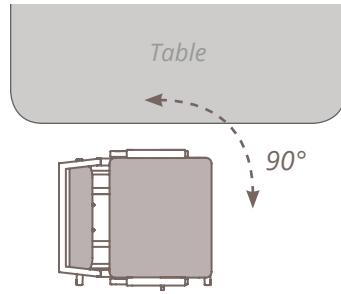
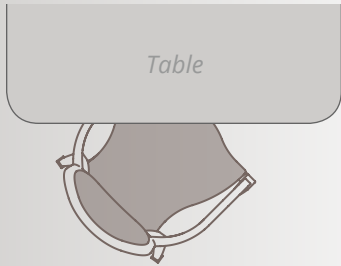

# HOW CHAIRS THAT **SWIVEL - LOCK - TURN - ROLL - BRAKE** ACTUALLY WORK



## TRADITIONAL SEATING

- Chair provides no movement when assisting a person up to the table
- Chair is placed close to the table and positioned at 45 degrees (restricting access)
- Table interferes with efforts of caregiver to get a person seated
- Caregiver required to **push-pull-shove-twist** when positioning a seated person to the table

## SWIVEL - LOCK

- The base of the chair remains stable. No wheels
- The seat swivels 90 degrees and locks automatically
- Provides full access to the chair seat
- Eliminates table interference when getting a person seated



## SWIVEL - LOCK, ROLL & BRAKE

- The seat swivels 90 degrees and locks automatically
- Provides full access to the chair seat
- Eliminates table interference when getting a person seated
- The chair can also be pulled away from the table providing additional clearance
- The chair rolls forward and backward (inline)
- Foot brakes attached to rear casters



## TURN, ROLL & BRAKE

- The chair turns 360 degrees
- Provides full access to the chair seat
- Eliminates table interference when getting a person seated
- Caregivers can move seated persons from table to table
- Allows the caregiver to bring the chair to the person requiring assistance
- Multiple brake options available



# T.2



The T2 Series is designed specifically for use in LTC communities and for in-home care settings. The design features of the T2 Series enables a community to match a chair's mobility features to the specific need of a resident (**5 Chairs - 1 Look**).



T2-841-22"

5 CHAIRS 1 LOOK



T2-841SWL-22"

Swivels...and Locks for Safety



T2-841-SWL-CC5

Swivels...Locks...Rolls...and Brakes for Safety



T2-841-22"-CC1

Turns...Rolls...and Locks for Safety

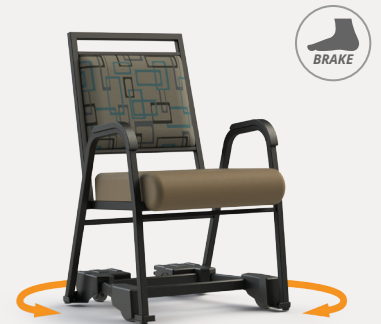

T2-841-22"-CC4

Turns...Rolls...and Brakes for Safety

60% - 70%

30% - 40% - Chairs with Mobility Options



Watch videos at [www.comfortek.com/5in1](http://www.comfortek.com/5in1)



# Who Benefits...

When chairs are designed to **Swivel...Turn...Roll...and Brake** for safety.



T-2

Contessa



## ...REDUCE

*Workplace Injuries*

*WC Claims / Absenteeism / Overtime*

*Furniture Costs...as the premature replacement of chairs is no longer required*

*Flooring Costs...as damage caused as a result of constant skidding is eliminated*



## ...CREATE

*Safer Workplace*

*A More Enjoyable Mealtime Routine*

*Healthier Work Environment*

*Better Retention of Care Staff*



## ...NURTURE

*Creating a More Enjoyable Mealtime Routine*

*Families Experience an Increased Sense of Dignity & Self-Worth*

*Enables Seniors to Care of Each Other*



**Reducing Stress / Anxiety  
for Both the  
Seated Person and the Caregiver**

**a  
better  
way...**

**Creating  
a More Enjoyable  
Mealtime Routine**